

# ENGLISH

## User manual



**Table of contents:**

1. SAFETY PRECAUTIONS AND PROCEDURES .....	2
1.1. Preliminary instruction.....	2
1.2. During use.....	2
1.3. After use.....	2
2. GENERAL DESCRIPTION .....	3
3. PREPARATION FOR USE .....	3
3.1. Initial checks .....	3
3.2. Power supply .....	3
3.3. Storage .....	3
4. NOMENCLATURE.....	4
4.1. Instrument description.....	4
4.2. Display description .....	4
4.3. Function key description .....	5
4.3.1. ON/OFF key.....	5
4.3.2. UTP and STP keys .....	5
4.3.3. GO key.....	5
4.3.4. ▼ and ▲/☀ keys.....	5
4.3.5. Auto Power OFF feature.....	5
5. OPERATING INSTRUCTIONS.....	6
5.1. Cabling test verify.....	6
5.2. Cabling errors.....	7
5.3. Split pairs explanation note.....	9
6. MAINTENANCE .....	10
6.1. General informations.....	10
6.2. Battery replacement .....	10
6.3. Cleaning.....	10
6.4. End of life .....	10
7. TECHNICAL SPECIFICATIONS .....	11
7.1. Technical specifications .....	11
7.2. General specifications.....	11
7.3. Environment.....	11
7.3.1. Environmental conditions .....	11
7.4. Accessories.....	11
7.4.1. Standard accessories.....	11
7.4.2. Optional accessories .....	11
8. SERVICE .....	12
8.1. Warranty conditions .....	12
8.2. Service.....	12

## 1. SAFETY PRECAUTIONS AND PROCEDURES

### CAUTION



For your own safety as well as that of the apparatus you are recommended to follow the procedures described in this instruction manual and carefully read all the notes preceded by the symbol . No compliance with the CAUTIONS and/or Instructions may damage the apparatus and/or its components or injure the operator.

### 1.1. PRELIMINARY INSTRUCTION

- Read this instruction manual and the instrument's one before starting use.
- Any instruction preceded by the caution symbol must be observed in order to avoid accidents or damages.
- Check that battery has been correctly placed.
- Only qualified personnel practicing applicable safety precautions must use this product.
- Do not perform any measurement under conditions beyond the limits specified in this manual.

### CAUTION



Connect the tester only to inactive cables. Connection to active telephone lines and networks may damage the instrument.

### 1.2. DURING USE

Read carefully the following recommendations and instructions:

### CAUTION



If the display shows the symbol "" interrupt testing and replace batteries. Never replace batteries while the instrument is connected to conductors.

- Do not use the instrument if damaged.
- Do not use the instrument outdoor.
- Do not perform measurements under environmental conditions beyond the limits specified in § 7.3.1.
- Do not expose the instrument to water splashes.

### 1.3. AFTER USE

- After using the instrument switch it off.
- Remove batteries if you expect not to use the instrument again for a long period.

## 2. GENERAL DESCRIPTION

The instrument allows the followed functions:

- Wire mapping test on LAN cables with RJ45 connector
- Test on UTP and STP cables
- Up to 6 error conditions identified
- Recognition of up to 8 remote units
- Pass/Fail indications
- Backlight
- Auto Power OFF

## 3. PREPARATION FOR USE

### 3.1. INITIAL CHECKS

This instrument was checked both mechanically and electrically prior to shipment. All possible cares and precautions were taken to let you receive the instrument in perfect conditions. Notwithstanding we suggest you to check it rapidly (eventual damages may have occurred during transport). Make sure that all standard accessories mentioned in § 7.4.1 are included. Should you have to return back the instrument for any reason please follow the instructions mentioned in § 8.

### 3.2. POWER SUPPLY

The instrument is battery supplied with 1x9V alkaline battery type IEC 6F22 included in the package. When the “” low battery indication symbol is displayed replace it immediately, following the instructions given in § 6.2. Don't replace the battery while the instrument is connected to the plant.

### 3.3. STORAGE

After a period of storage in extreme environmental conditions exceeding the limits mentioned in § 7.3 let the instrument return to normal measuring conditions before using it.

## 4. NOMENCLATURE

### 4.1. INSTRUMENT DESCRIPTION

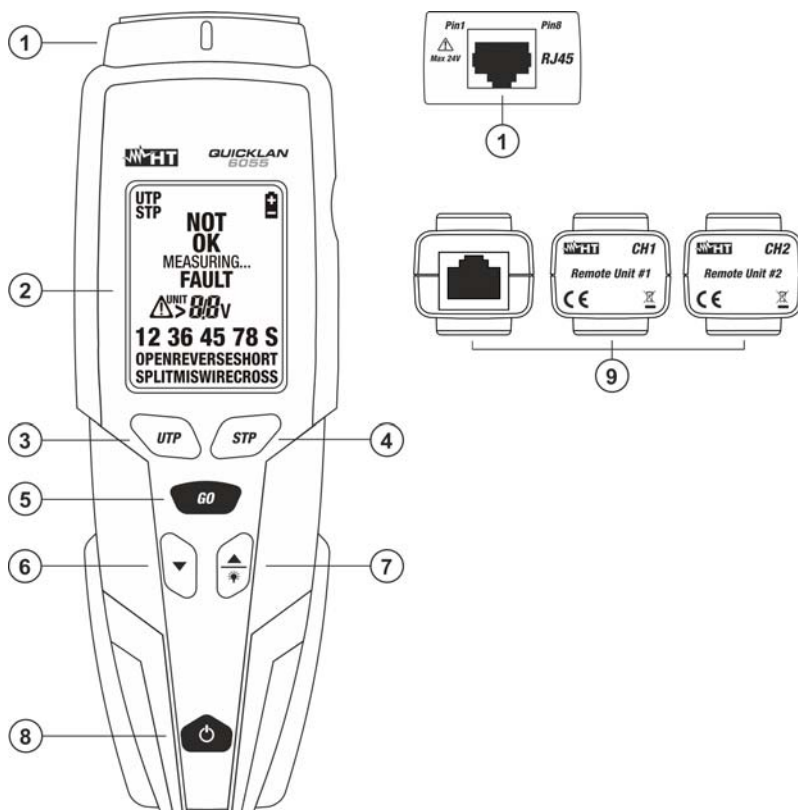

#### CAPTION:

1. RJ45 input terminal
2. LCD display
3. **UTP** key
4. **STP** key
5. **GO** key
6. ▼ key
7. ▲ key
8. **ON/OFF** key
9. Remote units #1 ~ #2

Fig. 1: Instrument description

### 4.2. DISPLAY DESCRIPTION

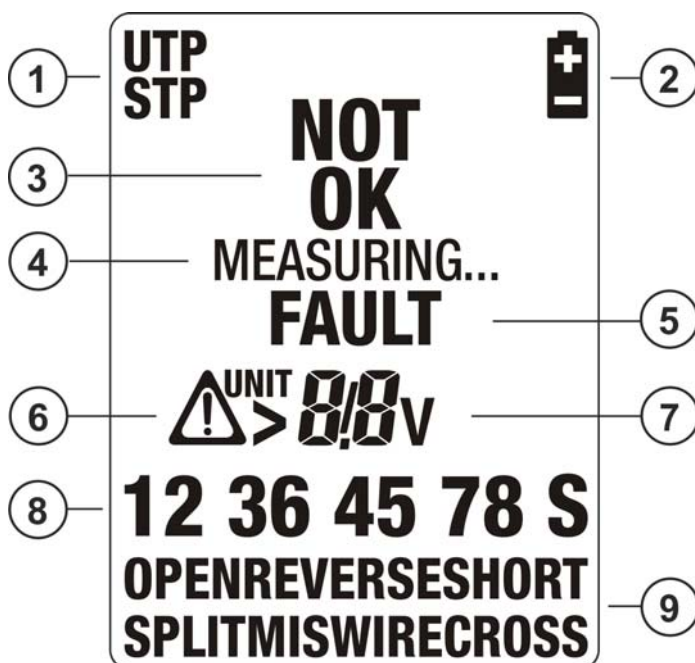

#### CAPTION:

1. Type of selected cable
2. Low battery indication
3. Final test outcome
4. Running test indication
5. Fault test indication
6. Caution and remote unit number indications
7. Error numbers and input voltage indications
8. RJ45 cable couples and S shield indications
9. Error type indications

Fig. 2: Display description

### 4.3. FUNCTION KEY DESCRIPTION

#### 4.3.1. ON/OFF key

By pushing **ON/OFF** key permits to turn on the instrument. For an instant all display segments light up, then the firmware release appears on the top right side. When “on” is displayed the instrument is ready to start (see Fig. 3)

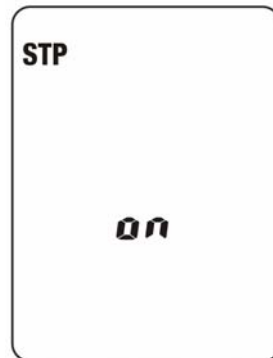

Fig. 3: Initial screen of instrument

By pushing long (>1s) **ON/OFF** key to switch off the instrument

#### 4.3.2. UTP and STP keys

By pressing **UTP** or **STP** keys it's possible to select the type of cable to be tested, with the following difference: STP performs also tests on the shield (continuity and proper connections) while UTP doesn't. Consequently STP must be pressed for all shielded cables such as: FTP (Foiled Twisted Pair cable), STP (Shielded Twisted Pair cable), SSTP (Shielded/Shielded Twisted Pair cable) and SFTP (Shielded/Foiled Twisted Pair cable)

### CAUTION



By default the selected cable is **STP**. Any time the instrument is turned off and on such type of cable is automatically selected

#### 4.3.3. GO key

By pushing **GO** key to activate the wire mapping test of LAN cable connected between the instrument's input and the remote unit used (see § 5.1).

#### 4.3.4. ▼ and ▲/☀ keys

By pushing ▼ or ▲/☀ keys for the selection of the errors detected by the instrument at the end of wire mapping test on cable (see § 5.2).

By pushing long (>2s) of **UNIT/☀** key permits to activate/disable the backlight

#### 4.3.5. Auto Power OFF feature

The instrument is provided with Auto Power OFF (APO) feature which automatically permits to switch it off after approx..4 minutes of idleness in order to preserve the internal battery.

## 5. OPERATING INSTRUCTIONS

### 5.1. CABLING TEST VERIFY

The wire mapping of RJ45 LAN cables is tested in accordance with its defined cabling layout. To test a cable perform the below steps:

1. Switch on the instrument by pushing the **ON/OFF** key
2. Select the type of cable **UTP** or **STP** under test (see § 4.3.2).
3. Connect the cable under test to the meter and to the remote unit by using if necessary through supplied patch cables (see Fig. 4)



Fig. 4: Instrument connection

4. Press **GO** key. The message “MEASURING...” is shown and the instrument performs all tests related to the selected type of cable



### CAUTION

The remote unit must be necessarily connected otherwise no measurement is performed

5. If cabling is correct, a screen like this is displayed (OK). The identification number refers to the remote identifier connected to the other end of the cable being tested.

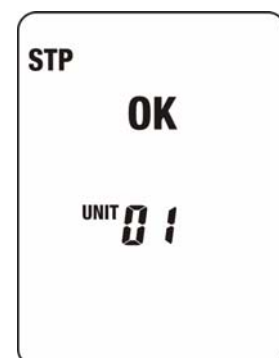

6. If cabling is not correct, a screen like this is displayed. Referring to this example:
- “NOT OK” indication and caution symbol means that the test have given some errors
  - “FAULT 1/3” means that the detected errors are 3, of which the first one is currently displayed. By pressing ▼ or ▲/ keys it’s possible to run over the remaining screens and display other cabling errors
  - Details on the detected error are given on the left side: e.g: the couple 1-2 is OPEN
7. If the instrument detects the presence of a voltage > **0.2V** on the RJ45 input, it shows the message in the screen on the right and do not perform the test. Eliminate the cause of the presence of voltage (e.g.: coupling due to the presence of electrical cables close to cable of LAN networks). **The maximum allowed voltage between inputs is 24V**



### CAUTION



It's indispensable to select the right type of cable. If UTP is selected although a STP cable is tested, test results may be not reliable due to the shield affecting the measurement.

## 5.2. CABLING ERRORS

Cabling error	Description	Visualization	Mapping
OPEN PAIR	One or both conductors of the pair are interrupted (open)		
REVERSED PAIR	The conductors of the same pair are reversed		



<p>SHORTED CABLES</p>	<p>Two conductors are in short circuit between each other</p>	<p>STP <b>NOT OK</b> <b>FAULT</b> ⚠ // <b>1 8</b> <b>SHORT</b></p>	<p>1 1 2 2 3 3 4 4 5 5 6 6 7 7 8 8 S S</p>
<p>TRANSPOSED (CROSSED) PAIRS</p>	<p>Two pairs are crossed</p>	<p>STP <b>NOT OK</b> <b>FAULT</b> ⚠ // <b>12 78</b> <b>CROSS</b></p>	<p>1 1 2 2 3 3 4 4 5 5 6 6 7 7 8 8 S S</p>
<p>MISWIRE</p>	<p>Generic cabling error, such as for example two conductors belonging to different pairs are exchanged</p>	<p>STP <b>NOT OK</b> <b>FAULT</b> ⚠ // <b>36 45</b> <b>MISWIRE</b></p>	<p>1 1 2 2 3 3 4 4 5 5 6 6 7 7 8 8 S S</p>
<p>SPLIT PAIRS</p>	<p>The pin to pin correspondence is hold, but physically the conductors of two pairs are crossed</p>	<p>STP <b>NOT OK</b> <b>FAULT</b> ⚠ // <b>36 45</b> <b>SPLIT</b></p>	<p>1 1 2 2 3 3 4 4 5 5 6 6 7 7 8 8 S S</p>

### 5.3. SPLIT PAIRS EXPLANATION NOTE

A LAN cable contains 8 conductors, twisted two by two thus forming 4 pairs: 1-2, 3-6, 4-5, 7-8. The error "SPLIT PAIRS" consists in the exchange of two conductors belonging to different pairs. The pin to pin correspondence seems intact, but physically the conductors of two couples are split. Such interaction hardly affects (or even makes impossible) the exchange of data at high frequency/speed.

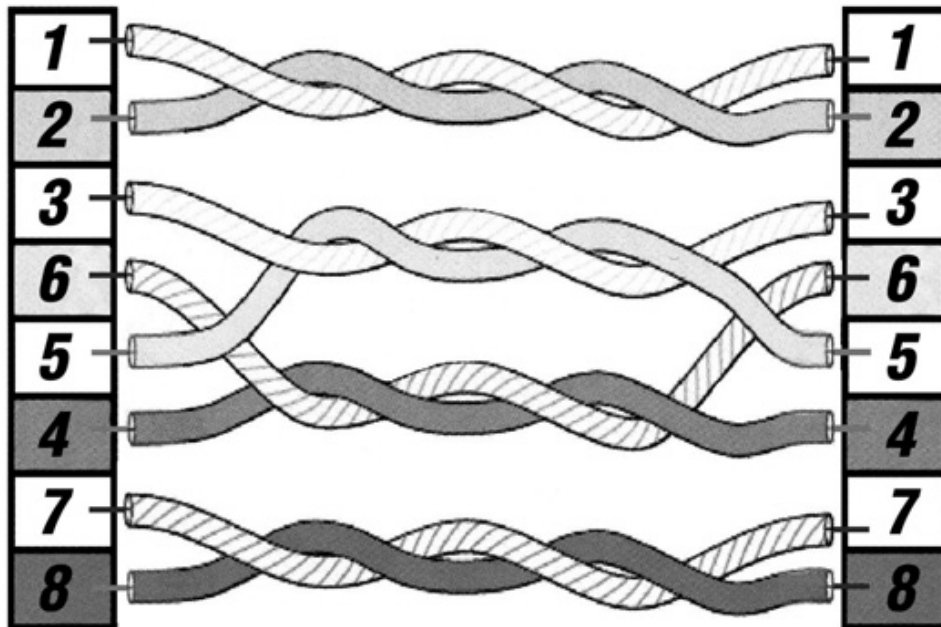

Fig. 5: Description of "Split pairs" error

#### CAUTION



The error condition "SPLIT PAIRS" is verified only when the cable mapping is fully correct.

## 6. MAINTENANCE

### 6.1. GENERAL INFORMATIONS

1. Whether in use or in storage, please do not exceed the specification requirements to avoid possible damages or dangers
2. Do not place this meter at high temperatures or humidity or expose it to direct sunlight
3. Be sure to turn off the meter after use. If you expect not to use the tester for a long time, remove the battery in order to avoid leakages of battery liquid that would damage the internal parts

### 6.2. BATTERY REPLACEMENT

When “” appears on the display, replace the battery.

#### CAUTION



Only skilled technicians can open the instrument and replace batteries. Before removing batteries disconnect the test leads from any energized circuits to avoid electrical shocks.

1. Switch off the instrument
2. Remove the temperature probe
3. Remove the battery cover
4. Remove the battery from the battery fastener
5. Set the new battery into battery fastener, and return it to the battery case
6. Replace the battery cover
7. Use the appropriate battery disposal methods for Your area

### 6.3. CLEANING

To clean the instrument use a soft dry cloth. Never use a wet cloth, solvents or water.

### 6.4. END OF LIFE



**CAUTION:** this symbol indicates that equipment and its accessories shall be subject to a separate collection and correct disposal.

## 7. TECHNICAL SPECIFICATIONS

### 7.1. TECHNICAL SPECIFICATIONS

#### Connectors

LAN input connectors RJ45

#### Cables which can be tested

Cable type UTP, STP  
Category CAT3, 5, 5E, 6, 6A, 7  
Reference guideline: TIA/EIA 568B  
Max height of use: 2000m (6562ft)  
Length up to 200m (656ft)<sup>(1)</sup>

(1) To perform the test "SPLIT PAIR" the cable must be at least 1m (3.3ft) long

### 7.2. GENERAL SPECIFICATIONS

#### Mechanical features

Dimensions (L x W x H): 190 x 65 x 45mm (7 x 3 x 2in)  
Weight (with battery): 235g (8 ounces)  
Dimensions rem.units (L x W x H): 30 x 25 x 27mm (1 x 1 x 1in)  
Weight remote units: 13g (0.5ounces)  
Mechanical protection: IP40

#### Power supply

Battery type 1x9V type IEC 6F22  
Battery life ca 600h (backlight OFF), ca 16h (backlight ON)  
Auto Power OFF; after 4 minutes of idleness (not disabled)

### 7.3. ENVIRONMENT

#### 7.3.1. Environmental conditions

Working temperature 0°C ÷ 40 °C (32°F ÷ 104°F)  
Relative humidity <80%RH  
Storage temperature 0°C ÷ 40°C; (32°F ÷ 104°F)  
Storage humidity <80%RH

**This product conforms to the prescriptions of the EMC directive 2014/30/EU  
This instrument satisfies the requirements of 2011/65/EU (RoHS) directive and  
2012/19/EU (WEEE) directive**

### 7.4. ACCESSORIES

#### 7.4.1. Standard accessories

- Remote unit #1 CH1
- Remote unit #2 CH2
- Patch cables RJ45/RJ45, STP, 20cm, 3 pcs YAAMS0000000
- Battery
- Carrying bag
- User manual

#### 7.4.2. Optional accessories

- Remote unit #3 and cable RJ45/RJ45 STP REM3
- Remote unit #4 and cable RJ45/RJ45 STP REM4
- Remote unit #5 and cable RJ45/RJ45 STP REM5
- Remote unit #6 and cable RJ45/RJ45 STP REM6
- Remote unit #7 and cable RJ45/RJ45 STP REM7
- Remote unit #8 and cable RJ45/RJ45 STP REM8
- Remote units #3 - #8 + 6 cables RJ45/RJ45 STP REM38

## 8. SERVICE

### 8.1. WARRANTY CONDITIONS

This instrument is guaranteed for one year against material or production defects, in accordance with our general sales conditions. During the warranty period the manufacturer reserves the right to decide either to repair or replace the product. Should you need for any reason to return back the instrument for repair or replacement take prior agreements with the local distributor from whom you bought it. Use only original packaging. Any damage occurred in transit due to not original packaging will be charged anyhow to the customer.

The warranty doesn't apply to:

- Accessories and batteries (not covered by warranty).
- Repairs made necessary by improper use (including adaptation to particular applications not foreseen in the instructions manual) or improper combination with incompatible accessories or equipment.
- Repairs made necessary by improper shipping material causing damages in transit.
- Repairs made necessary by previous attempts for repair carried out by not skilled or unauthorized personnel.
- Instruments for whatever reason modified by the customer himself without explicit authorization of our Technical Dept.

The contents of this manual may not be reproduced in any form whatsoever without the manufacturer's authorization.

**Our products are patented and our logotypes registered. We reserve the right to modify specifications and prices in view of technological improvements or developments which might be necessary.**

### 8.2. SERVICE

Shouldn't the instrument work properly, before contacting your distributor make sure that batteries are correctly installed and working, check the test leads and replace them if necessary. Should the instrument still operate improperly check that the operation procedure is correct and conforms to the instructions given in this manual. If the instrument is to be returned to the after-sales service or to a dealer transportation costs are on the customer's behalf. Shipment shall be however agreed upon. A report must always be enclosed to a rejected product stating the reasons of its return. To ship the instrument use only the original packaging material; any damage that may be due to no-original packing shall be charged to the customer.