

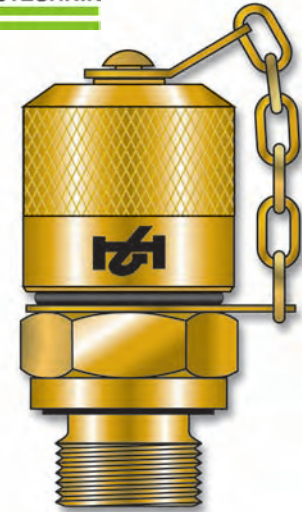

# MINIMESS®-1620 Test Points

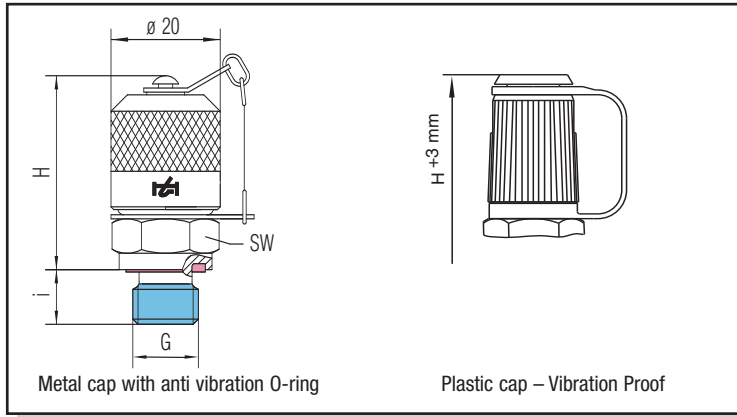
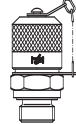
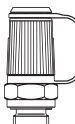

Thread G	Type of seal A	Torque in Nm	Technical data				Material: Free cutting steel 1.0718  Metal cap	Part-number with NBR - sealing	Material: Free cutting steel 1.0718  Plastic cap	Part-number with NBR - sealing	Material: Stainless steel 1.4571  Metal cap	Part-number with FKM - sealing
			p max	H in mm	i in mm	SW in mm						
M 8 x 1*	Form G	6	25 MPa	41	8,5	17	<b>2103-01-32.00</b>	2103-30-32.00	on request	2703-01-33.10		
M 10 x 1		12		37,5	8,5	17	<b>2103-01-33.00</b>					
M 12 x 1,5	Form F	30	63 MPa	36	10	17	<b>2103-01-13.00</b>	2103-30-13.00	on request	2703-01-14.10		
M 14 x 1,5		40		36	10	19	<b>2103-01-14.00</b>					
M 16 x 1,5		60		36	10	22	<b>2103-01-15.00</b>					
M 14 x 1,5	Form E**	45	40 MPa	35,5	11	19	<b>2103-01-96.00</b>	2103-30-96.00	on request	2703-01-17.10		
ISO 228-G 1/8	Form F	18		38	8	17	<b>2103-01-17.00</b>					
ISO 228-G 1/4		40	63 MPa	36	10	19	<b>2103-01-18.00</b>	2103-30-18.00	2703-01-18.10			
ISO 228-G 3/8		60		36	10	22	<b>2103-01-16.00</b>					
1/8 NPTF	Form H	–	40 MPa	33	9,5	17	<b>2103-01-46.00</b>	2103-30-46.00	on request	2703-01-47.10		
1/4 NPTF		–		33	16,5	17	<b>2103-01-47.00</b>					
7/16-20 UNF	Form E	20	63 MPa	37	9	17	<b>2103-01-21.00</b>	2103-30-21.00	on request	on request		
9/16-18 UNF		35		36	10	19	<b>2103-01-53.00</b>					
ISO 7/I-R 1/8	Form C	–	40 MPa	33	13	17	<b>2103-01-40.00</b>	2103-30-40.00	on request	on request		
ISO 7/I-R 1/4		–		63 MPa	33	13	17				<b>2103-01-41.00</b>	2103-30-41.00

\* M8x1 - Please do not use for new machinery design.  
\*\* Form E – ISO 6149-2.

### Option

For sealing in FKM (Viton) Exchange end digits from 00 to 10	<b>10</b>
--	-----------

Other materials, designs, sealing and screw-in threads on request.  
We reserve the right to carry out technical modifications.

# MINIMESS®-1620 Test Points Metric DKO, Tee Adaptors - 1620

For solder free screw-in pipe connections according to DIN 2353; free-cutting steel 1.0718; sealing NBR

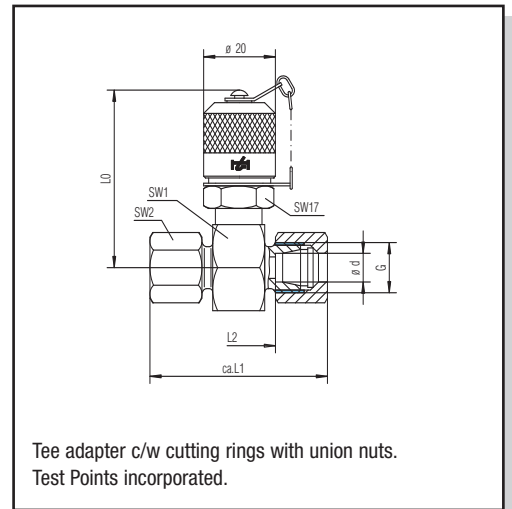
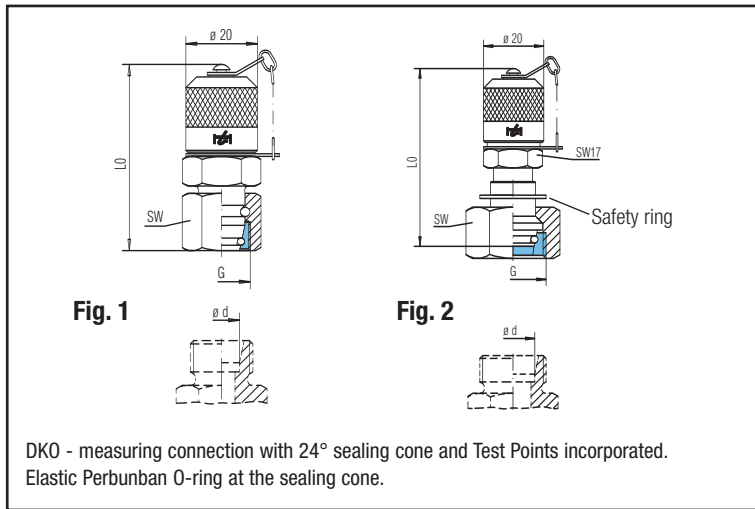

Series Ø d	p max	Thread G
L 6	31,5 MPa	M 12 x 1,5
L 8		M 14 x 1,5
L 10		M 16 x 1,5
L 12		M 18 x 1,5
L 15		M 22 x 1,5
L 18		M 26 x 1,5
L 22	16 MPa	M 30 x 2
L 28		M 36 x 2
L 35		M 45 x 2
L 42		M 52 x 2

Fig.	L <sub>0</sub>	SW	Part-number
1	52	14	<b>2103-93-06.00</b>
	52	17	<b>2103-93-08.00</b>
	52	19	<b>2103-93-10.00</b>
	52	22	<b>2103-93-12.00</b>
	52	27	<b>2103-93-15.00</b>
	52	32	<b>2103-93-18.00</b>
2	60	36	<b>2103-40-22.00</b>
	61	41	<b>2103-40-28.00</b>
	63	50	<b>2103-40-35.00</b>
	63	60	<b>2103-40-42.00</b>

L <sub>1</sub>	L <sub>2</sub>	L <sub>0</sub>	SW <sub>1</sub>	SW <sub>2</sub>	Part-number
50,5	20,5	49,5	24	14	<b>2103-11-06.00</b>
50,5	20,5	49,5	24	17	<b>2103-11-08.00</b>
52,5	22,5	49,5	24	19	<b>2103-11-10.00</b>
52,5	22,5	49,5	24	22	<b>2103-11-12.00</b>
54,5	24,5	52,5	30	27	<b>2103-11-15.00</b>
56,5	23,5	53,5	32	32	<b>2103-11-18.00</b>
60,5	27,5	55,5	36	36	<b>2103-11-22.00</b>
60,5	27,5	58	41	41	<b>2103-11-28.00</b>
68,5	25,5	60,5	46	50	<b>2103-11-35.00</b>
70,5	24,5	65	55	60	<b>2103-11-42.00</b>

Series Ø d	p max	Thread G
S 6	63 MPa	M 14 x 1,5
S 8		M 16 x 1,5
S 10		M 18 x 1,5
S 12		M 20 x 1,5
S 14	M 22 x 1,5	
S 16	40 MPa	M 24 x 1,5
S 20		M 30 x 2
S 25		M 36 x 2
S 30	M 42 x 2	
S 38	31,5 MPa	M 52 x 2

Fig.	L <sub>0</sub>	SW	Part-number
1	52	17	<b>2103-94-06.00</b>
	52	19	<b>2103-94-08.00</b>
	52	22	<b>2103-94-10.00</b>
	52	24	<b>2103-94-12.00</b>
2	63	27	<b>2103-41-14.00</b>
1	52	30	<b>2103-94-16.00</b>
	63	36	<b>2103-41-20.00</b>
	64,5	46	<b>2103-41-25.00</b>
	66	50	<b>2103-41-30.00</b>
	69	60	<b>2103-41-38.00</b>

L <sub>1</sub>	L <sub>2</sub>	L <sub>0</sub>	SW <sub>1</sub>	SW <sub>2</sub>	Part-number
54,5	24,5	49,5	24	17	<b>2103-12-06.00</b>
54,5	24,5	49,5	24	19	<b>2103-12-08.00</b>
56,5	23,5	49,5	24	22	<b>2103-12-10.00</b>
56,5	23,5	49,5	24	24	<b>2103-12-12.00</b>
62,5	26,5	51	27	27	<b>2103-12-14.00</b>
62,5	25,5	52,5	30	30	<b>2103-12-16.00</b>
68,5	25,5	55,5	36	36	<b>2103-12-20.00</b>
74,5	26,5	58	41	46	<b>2103-12-25.00</b>
80,5	27,5	60,5	46	50	<b>2103-12-30.00</b>
91	29	65	55	60	<b>2103-12-38.00</b>

## Options

All sealing made of Viton with metal cap (when ordering, exchange end digits from 00 to 10)	<b>10</b>
With mounted plastic cap (when ordering, exchange end digits from 00 to 90)	<b>90</b>
All sealing made of Viton with plastic cap (when ordering, exchange end digits from 00 to 95)	<b>95</b>

## MINIMESS®-1620 Test Points Metric DKO 1620 Male/Female Tee Adaptors

For solder free screw-in pipe connections according to DIN 2353

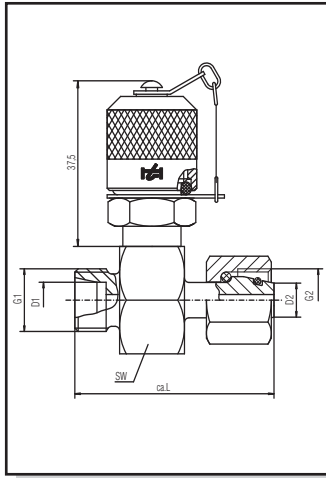

Series	p max	G1	D1	G2	D2	SW	L	Part-number
L 6	31,5 MPa	M 12 x 1,5	6	M 12 x 1,5	6	24	44,5	2103-KL-06.00
L 8		M 14 x 1,5	8	M 14 x 1,5	8	24	44,5	2103-KL-08.00
L 10		M 16 x 1,5	10	M 16 x 1,5	10	24	47,5	2103-KL-10.00
L 12		M 18 x 1,5	12	M 18 x 1,5	12	24	48,5	2103-KL-12.00
L 15		M 22 x 1,5	15	M 22 x 1,5	15	30	51,5	2103-KL-15.00
L 18	16 MPa	M 26 x 1,5	18	M 26 x 1,5	18	32	55,5	2103-KL-18.00
L 22		M 30 x 2	22	M 30 x 2	22	36	58,5	2103-KL-22.00
L 28		M 36 x 2	28	M 36 x 2	28	41	59	2103-KL-28.00
L 35		M 45 x 2	35	M 45 x 2	35	46	68	2103-KL-35.00
L 42		M 52 x 2	42	M 52 x 2	42	55	68	2103-KL-42.00

Series		G1	D1	G2	D2	SW	L	Part-number
S 6	63 MPa	M 14 x 1,5	6	M 14 x 1,5	6	24	46,5	2103-KS-06.00
S 8		M 16 x 1,5	8	M 16 x 1,5	8	24	48,5	2103-KS-08.00
S 10		M 18 x 1,5	10	M 18 x 1,5	10	24	49,5	2103-KS-10.00
S 12		M 20 x 1,5	12	M 20 x 1,5	12	24	50	2103-KS-12.00
S 14		M 22 x 1,5	14	M 22 x 1,5	14	27	53,5	2103-KS-14.00
S 16	40 MPa	M 24 x 1,5	16	M 24 x 1,5	16	30	56,5	2103-KS-16.00
S 20		M 30 x 2	20	M 30 x 2	20	36	64,5	2103-KS-20.00
S 25		M 36 x 2	25	M 36 x 2	25	41	66	2103-KS-25.00

## MINIMESS®-1620 Test Points 1620 Bulkhead Adaptors

For solder free screw-in pipe connections according to DIN 2353, to MINIMESS® - 1620 Test Points, NBR sealing

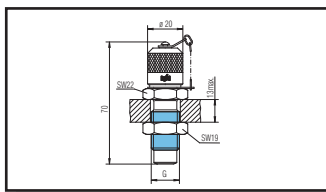
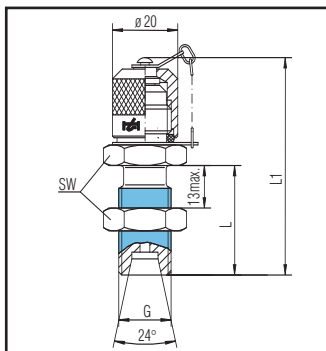

Thread G	p max	Connectoin	L in mm	L <sub>1</sub> in mm	SW in mm	Part-number
M 12 x 1,5	31,5 MPa	L 6	34	67	17	2103-04-22.00
M 14 x 1,5		L 8	34	67	19	2103-04-23.00
M 16 x 1,5		L 10	33,5	66,5	22	2103-04-18.00
M 14 x 1,5	63 MPa	S 6	36	69	19	2103-04-24.00
M 16 x 1,5		S 8	33,5	66,5	22	2103-04-25.00
M 18 x 1,5		S 10	37	70	24	2103-04-26.00

Thread G	p max	Connectoin	Part-number
M 16 x 2	63 MPa	Both sides for MINIMESS® 1620 (M 16 x 2)	2103-04-16.00

## MINIMESS®-1620 Test Points

### 1620 Standpipe adaptor 37° - edged screwing SAE J514

NBR sealing

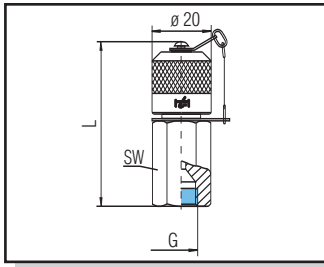

Thread G	p max	Pipe Ø in mm	Pipe Ø in inch	L in mm	SW in mm	Part-number
7/16-20 UNF	60 MPa	6	1/4"	55	17	2103-85-21.00
1/2 -20 UNF	42 MPa	8	5/16"	56,5	17	2103-85-22.00
9/16-18 UNF	31,5 MPa	10	3/8"	57,5	19	2103-85-23.00
3/4- 16 UNF		12	1/2"	60,5	22	2103-85-24.00

## MINIMESS®- pressure gauge connection for bulkhead fitting

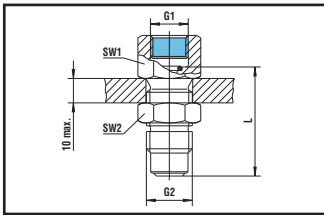

Internal thread G1	p max	Connection G2	L in mm	SW in mm	Note	Part-number
ISO 228-G 1/4	63 MPa	1620 / M 16 x 2	38	19	Without return valve	2103-05-11.00
ISO 228-G 1/2			42,5	27		2103-05-12.00
1/4 NPT			-	19		2103-05-23.00

## MINIMESS®-1620 pressure gauge – direct connection

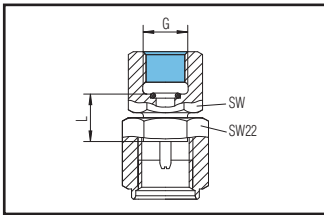

Internal thread G	p max	L in mm	SW in mm	Part-number
ISO 228-G 1/4	63 MPa	14,5	19	2103-07-11.62
ISO 228-G 1/2		17	27	2103-07-12.62
1/4 NPT		-	19	2103-07-23.62

## MINIMESS®-1620

### 90° Swivel screw connection

NBR sealing

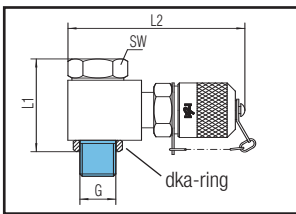

Thread G	p max	L <sub>1</sub> in mm	L <sub>2</sub> in mm	SW in mm	Part-number
ISO 228-G 1/4	63 MPa	34,5	64,5	19	2115-22-34.00

Sealing on screw-in thread (hollow screw) via dka-ring, on hexagon via Gi-ring (NBR). Other options on request.

## MINIMESS®-1620 hose adaptor

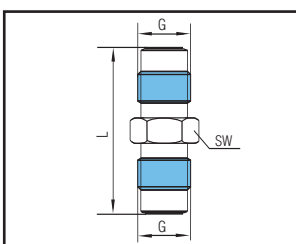

Thread G	p max	L in mm	SW in mm	Note	Part-number
M 16 x 2	63 MPa	42	17	Without return valve	2146-01-00.00

Other materials, further executions, sealing and screw-in threads on request.

# MINIMESS®-1620 p/T Test Points

for pressure and temperature measurement

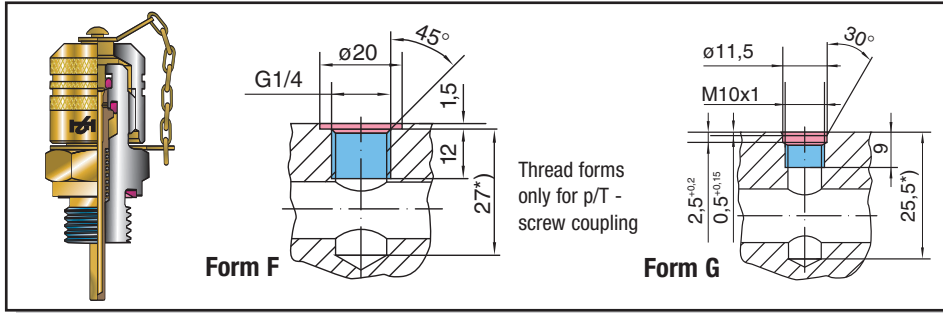
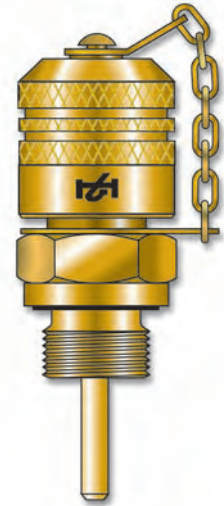

\*) = recommended min. depth of drill

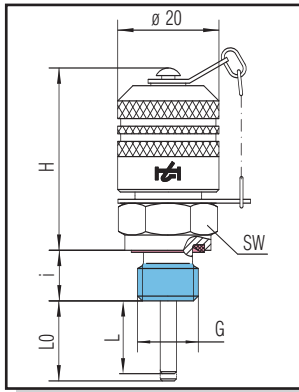

Thread G	Type of sealing A	Torque in Nm	Technical data						SW in mm	Part-number with NBR - sealing
			p max	H in mm	i in mm	L <sub>0</sub> in mm	L in mm			
ISO 228-G 1/4	Form F	40	63 MPa	36,5	10	16	14,5	19	2149-04-15.13	
M 10 x 1	Form G	12		38	8,5	16	14,5	17	2149-04-19.13	

L<sub>0</sub> = max. immersion depth in coupled state, L = not coupled state

## Option

For FKM (Viton) - exchange end digits from 13 to 53

53

Other materials, further options, sealing and screw-in threads on request.  
We reserve the right to carry out technical modifications.